

Sliding wear behaviour of walnut shell powder filled vinyl ester/WSP green composites

Shahryar Pashaei*, Soleyman Hosseinzadeh

Department of Chemistry, Payame Noor University, P.O. BOX 19395-3697 Tehran, Iran

Received: 12 February 2016, Accepted: 13 June 2016, Published: 13 June 2016

Abstract

Polyvinyl ester green composites were synthesized with walnut shell powder (WSP) by in-situ polymerization technique. The green composites have been evaluated for mechanical properties such as tensile strength, tensile modulus and hardness. Sliding wear loss, specific wear rate and coefficient of friction were investigated using computerized pin-on-disc machine at normal applied loads of 20, 30 and 40N; at a sliding velocity of 1.5 m/s and at two abrading distances viz., 100 and 200 m. The results indicate that the wear volume loss increases with increasing abrading distance/load. It was found that WSP filled vinyl ester composites exhibit lower wear rate and higher coefficient of friction as compared to vinyl ester green composites. Further, the worn surfaces were examined by scanning electron microscopy (SEM) to give insight in to the wear mechanism while their mechanical properties were investigated using tensile strength, tensile modulus and hardness test machines.

Keywords: Walnut shell powder; specific wear rate; coefficient of friction; scanning electron microscopy.

Introduction

A composite material is a system that combines two or more micro or macro constituents that differ in form and chemical composition which are essentially insoluble in each other. The particulate reinforced cellulose green composites are gaining importance nowadays due to their low cost and west material in the agriculture. Cast cellulose matrix particle reinforced composites have higher specific strength, specific modulus, hardness and good wear resistance as compared to unreinforced polymers. These materials have emerged as the employment of polymeric composites

in tribological purposes such as gears, brakes, clutches, bearings and transmission belts. the wear behaviors of the reinforcement green composites play an important role in structural and automobile applications owing to their exceptional properties of high specific strength, excellent fracture toughness, thermal, electrical, corrosive resistance and greatly influence their surface structure. Wear refers to the progressive removal of material from a surface and plastic deformation of material on a surface due to the mechanical action of the other surface.

Wear behavior of a material depends upon the surface material, the shape of

*Corresponding author: Shahryar Pashaei

Tel: +98 (914) 1672215, Fax: +98 (44) 33859003

E-mail: shahryarpashaei@yahoo.com

the contacting surfaces, environment, operating conditions, crystal structure, grain size, and grain boundaries. Abrasive wear takes place due to rubbing of softer surface by the harder surface. In the case of ductile materials, hard particles or hard asperities result in plastic flow of softer material. Abrasion is categorized depending on the types of contact, as well as contact environment. Depending on the types of contacts, abrasive wear can be classified as two-body and three-body wear.

In current years, a lot of research has studied the advantages of thermoset matrix in composite applications. Fiber reinforced polymer (FRP) composites acquired an important space in the field of composite materials. FRP composites have been widely used in various applications, i.e. automotive, aerospace, marine, defense, and sports goods because of their high specific strength and stiffness. These materials provide design flexibility, high durability, excellent corrosion resistance and lightweight which make them attractive material in these applications [1,2]. The fiber which acts as reinforcing agent in the reinforced plastics may be either synthetic or natural. Various types of synthetic (or man-made) fibers have been developed such as aramid, Kevlar, glass, polyether ether ketone (PEEK), nylon, rayon, acrylic, olefin, polyester, vinyl, etc. [3].

The growing ecological concern and governmental rules lead to rise in the demand of the natural fibers as a substitute of synthetic fibers [4-6]. The natural fibers such as hemp, sisal, jute, flax and bamboo are renewable and biodegradable in nature and possess high technical qualities such as good modulus and specific strength, low density and cost, and reduced dermal and respiratory irritation [7]. The mechanical properties of natural fibers, particularly hemp, sisal, flax, and jute

are relatively good, and may compete with glass fiber in terms of specific strength and modulus [8].

The novelty of the current research work is to develop low cost eco-friendly polymer composite materials for wear resistance applications using walnut shell powder. For the first time, the effect of varying amounts of walnut shell powder loaded vinyl ester green composites on the physical, mechanical and sliding wear behavior properties of polymer green composites have been investigated in this paper.

Experimental

Materials

Vinyl ester resins are widely used thermosets in commercially developed composite material applications because of their versatility. For example, filler, reinforcements and uncured vinyl ester resins are blended with coupling agents, catalyst, accelerator, promoter and other additives in the preparation of green composites. A dispersant (dispersing agent) can be used to minimize the viscosity of the vinyl ester resin during the mixing process and generally leads to better particle dispersion. Air release agents and a hardener are employed to promote the cure of vinyl ester-based green composites. The vinyl ester, VRP-2121 used as polymer matrix that viscosity of resin 650 cPa at 25 °C and specific gravity of resin is 1.125 at 25 °C. The cobalt octoate and methyl ethyl ketone peroxide (MEKP) were used as promoter and catalyst, respectively from M/s. Swathi Chemical, Bangalore India. The walnut shell powder has been parched as a byproduct food industrial as lignocellulosic filler for green composites.

Preparation of green composites

In this study, different amounts viz., 0,3,6 and 10 wt. % of walnut shell powder was added to the liquid. A

mechanical stirrer was used for dispersion of fillers into polymer matrix for 3 h at room temperature to complete the dispersion. The MEKP and cobalt octoate have been poured at a ratio of 100:1.4:1.4 by weight while stirring slowly around 10 min. The mixture was degassed and cured at room temperature for 24 h. Finally, the composites and neat polymer were post-cured at 80 °C for 4 h. The cured vinyl ester laminates have been investigated by different methods [9].

Techniques

Testing of Physical and Mechanical Properties

The prepared vinyl ester/WSP green composites were characterized for physical properties such as density and surface hardness according to ASTM D785 and ASTM D 2240 methods respectively. The physical properties of a composite material system can be as important as mechanical properties in assessing suitability for a particular application. Density plays a key role for designing an engineering component or deciding the application of a material particularly where weight is an important factor. Thus, it is necessary to determine the density of the composites fabricated for this study. The theoretical density (ρ_{ct}) of composites in terms of weight fraction is obtained using the relation given by Agarwal and Broutman [10].

$$\rho_{ct} = \frac{1}{\frac{w_f}{\rho_f} + \frac{w_m}{\rho_m}} \quad (1)$$

where, w and ρ designates the weight fraction and density, respectively. The suffix f , m and ct represent the filler, matrix and the composite materials, respectively. The actual density (ρ_{ac}) of the composites is determined by simple water immersion technique. By using the theoretical and experimental density of composites, the volume fraction of

voids (V_v) in the composites is determined using the following equation:

$$V_v = \frac{\rho_{ct} - \rho_c}{\rho_{ct}} \quad (2)$$

The tensile behavior of the blends were measured using JJ Lloyds Universal Testing Machine, model Z20, 20 KN, USA as per ASTM D-638 test method at a crosshead speed of 50 mm/min and a gauge length of 50 mm. The test specimens were rectangular in shape with dimensions 120 x 15 x 3 mm³. Minimum five samples were tested at room temperature for each formulation and the average values are reported. Hand operated durometer was used to measure the surface hardness of the prepared composites. Pin-on-disc machine, model POD-WTM-01, Contech micro systems make, 110 mm disc diameter, 8 mm disc thickness, surface roughness of 25 μ m and hardness 62 HRC was used for evaluating the sliding wear frictional properties of the composites as per the ASTM G99-04 method. The test specimens were weighed and initial weights were recorded using a high precision digital electronic balance after thorough cleaning. After recording the initial weight, the specimen was fixed to the holder such that the flat face of the specimen comes in contact with the rotating hardened steel disc as shown in Figure 1. The setup had an arrangement to vary the motor speed and consequently, the rpm of the disc. At a sliding velocity of 1.5 m/s, at two sliding distances of 100 and 200 m, the composite samples were subjected to varying applied loads of 20, 30 and 40 N. The final weights of the specimens were recorded and the wear loss in weight was calculated. The specific wear rate (K_S , g/N-m), was calculated from the equation, $K_S = W/F_N \times d$;

where, W is the weight loss in grams, F_N is the normal load in Newton, d is the sliding distance in meters. The coefficient of friction was calculated

from the equation: $\mu = F_f / F_N$; where, F_f is the frictional force (N) and μ is the coefficient of friction.

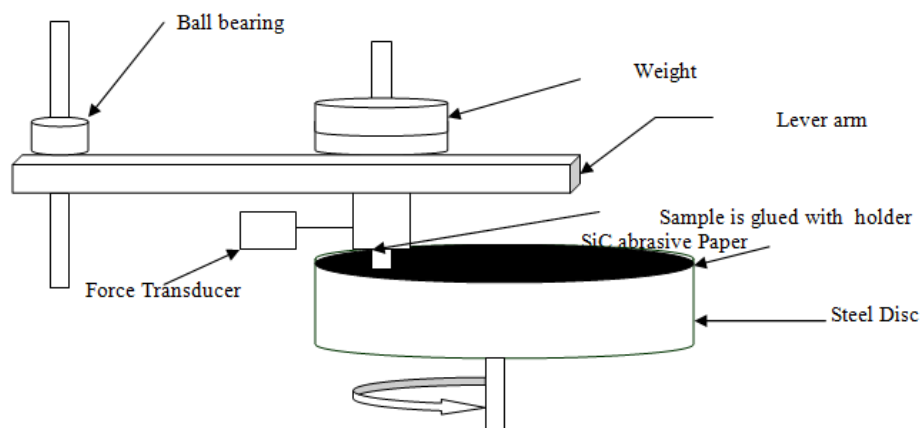

Figure1. Pin-on -disc machine set up

Scanning Electron Microscopy

Microstructures of the abraded composite samples were examined using a scanning electron microscope (model JEOL JSM-6480LV). Before taking micrographs, a thin film of platinum was vacuum-evaporated onto the surface of the samples in order to enhance the conductivity of the samples. The composite samples were mounted on stubs with silver paste.

Results and discussion

Physical properties

The theoretical density, experimental density and the corresponding void fraction of the composites have been shown in Table 1. It was noticed that the values of theoretical density are not equal to the experimental density of the

prepared composites. This difference in the theoretical and experimental density of the composites is the measure of voids or pores present in it. The presence of voids in composites significantly affects its mechanical properties directly or indirectly. From the Table1, it was noticed that the addition of walnut shell powder in the vinyl ester resin led to rise in void fraction of the green composites. The natural fibers consist of lumens in its cellular structure which acts as void. Thus, it may be the reason of increase in void content with the increase in fiber loading. Similar trend is also observed by previous researchers [11,12].

Table 1. Comparison between experimental and theoretical density and physical properties of WSP loaded vinylester green composites

WSP content in vinylester (wt. %)	Density (g/cc)		Void Fraction (%)	Tensile strength (MPa)	Elongationat break (%)	Young's modulus (MPa)
	Expt.	Theor.				
0	1.170	-	-	8.3	1.93	2736
3	1.176	1.182	0.5	5.3	1.03	3031
6	1.185	1.210	2.1	3.3	0.63	3204
10	1.195	1.25	4.4	3.2	0.62	3258

Surface hardness is a property measured laterally, whereas the modulus is measured longitudinally. The measured values of shore D hardness are given in Figure 2. The Figure 2 shows that with increase in filler loading, the hardness of the green composites increases. The increase in hardness may be due to walnut shell

powder as rigid material and brittle nature of lignocellulosic filler. This increase is in total agreement with previous results; the addition of a more stiff lignocellulosic filler together with the crystallinity increase provided by the nucleating phenomena, leads to increased hardness values [13,14].

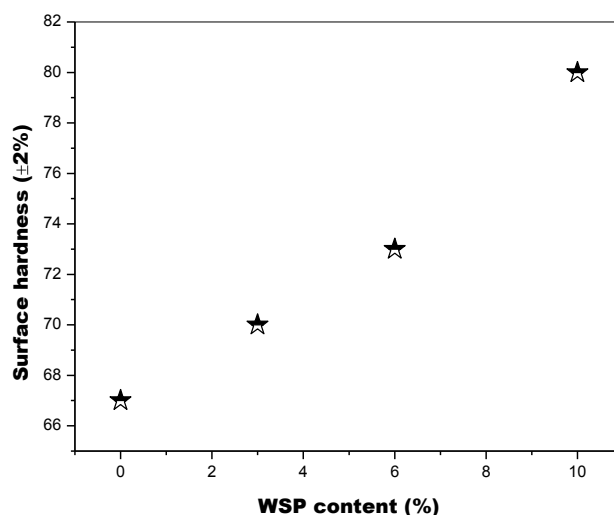

Figure 2. The plot of surface hardness as a function of WSP content for vinyl ester/WSP green composites

The variation of the tensile strength and modulus of neat polymer and WSP loaded vinyl ester green composites is shown in Figure 3. From the Figure 3, it was noticed that both the tensile

strength and modulus are improving with increase in WSP loading. This shows an effective and uniform stress transfer within the composite after the incorporation of filler into matrix. It has

been reported in their study that the tensile modulus depends mainly on the filler volume fraction and not on the physical structure of the filler. It has

been shown that the composite with 10 wt.% WSP loading indicated better tensile strength and modulus as compared to other composites.

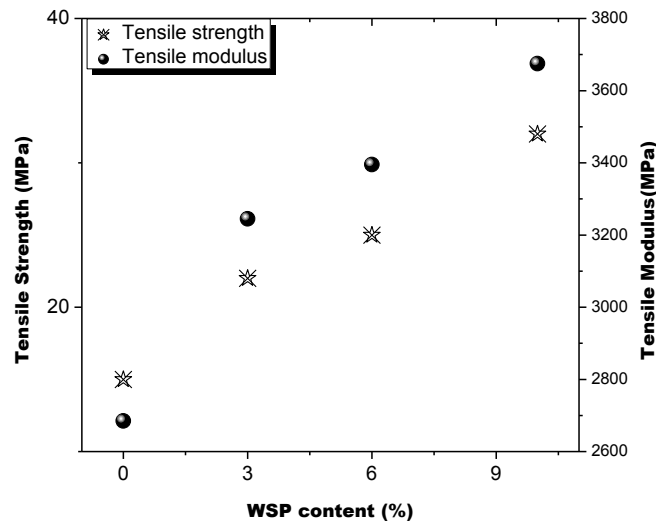

Figure 3. Effect of WSP content loading on tensile properties of Green composites

Wear loss

Figure 4(a-b) shows the effect of normal load on the wear loss of composites keeping other parameters constant (i.e. at sliding velocity: 1.5 m/s, sliding distance: (100 m, 200 m) and abrasive size: 300 μm). According to Figure 4, the wear loss of composites increases with increase in normal load at both abrading distances. Similar observations have also been reported by

other researchers for woven glass fabrics reinforced composites. The increase in wear loss at higher load may be due to thermal softening [15]. Furthermore, the observed wear loss decreases as the walnut shell powder content in the composites increases. It can also be observed from Figure 4 that bare vinyl ester shows maximum wear loss irrespective of different normal load.

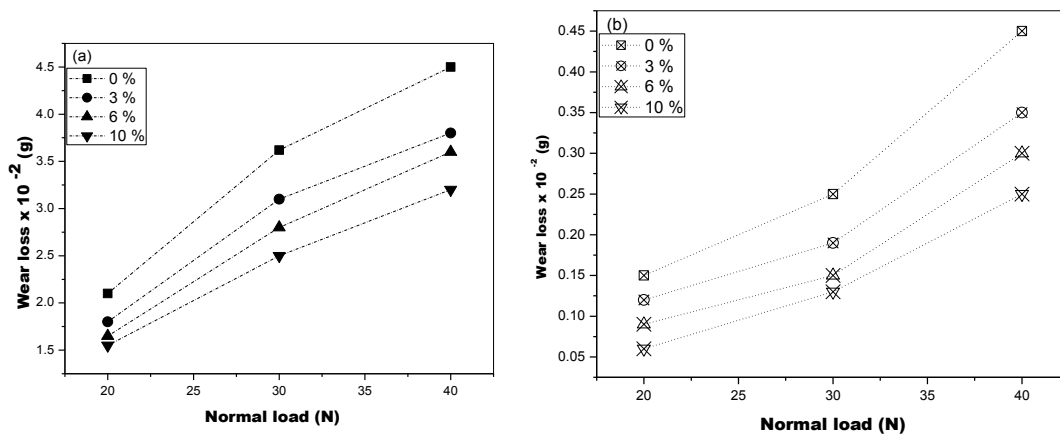

Figure 4. Effect of normal load on wear loss of WSP loaded vinyl ester green composites at sliding distance (a) 100 m and (b)200 m

From the Figure 5(a-b), it was noticed that reduction in specific wear rate with increase in walnut shell powder content in VE/WSP composite is due to the transfer film formed on the counterface, which acts as effective barrier to prevent large-scale

fragmentation of polymer matrix. It is well known that the wear behavior of a polymer sliding against a metal is strongly influenced by its ability to form a transfer film on the counterface [16].

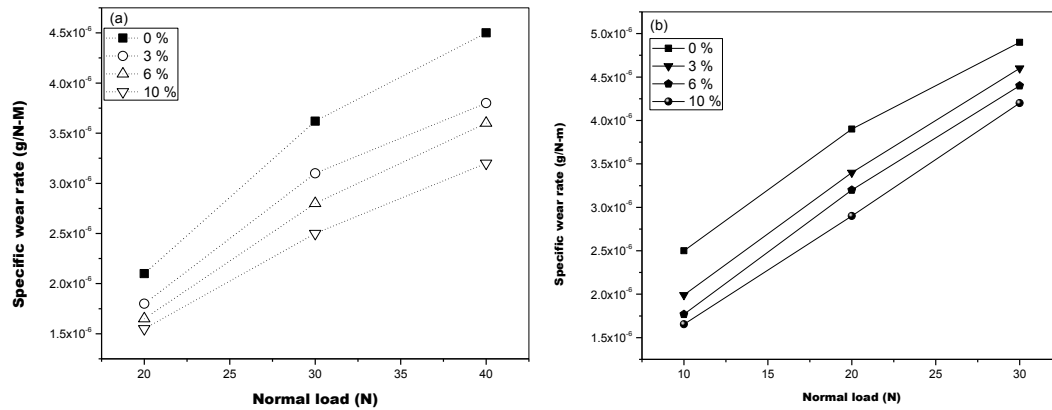

Figure 5. Influence of applied load on specific wear rates of walnut shell powder incorporated composites at different sliding distances of; (a) 100 m and (b) 200 m

Coefficient of friction

The coefficient of friction of neat vinyl ester and green composites as a function of normal load is shown in Figure 6 (a-b) at two abrading distances viz., 100 and 200 m. Owing to changes in the real area of contact and shear strength of polymer, in most sliding tests, the run-in friction precedes the steady state friction [17]. From the Figure 6 (a-b), it was obtained that all composites exhibit higher coefficient of friction than neat vinyl ester. It has also been observed that with the increase in normal load the coefficient of friction of the samples increases up to a certain value but further increase in abrading distance decreases the coefficient of friction of the samples. The increase in

coefficient of friction of the pure vinyl ester as well as its composites with the increase in normal load may be due to increased surface contact, whereas the decrease in coefficient of friction may be due to the occurrence of thermal softening process during wear [18]. The coefficient of friction increases with increase in normal load due to the changes in the real area of contact [18]. All composite materials exhibit the similar trend. During moulding as polymer cools in the mould, a skin is formed over the surface [19]. This skin is harder than the inside material. The changes in real area of contact and formation of transfer film in addition to the formation of skin influence the coefficient of friction.

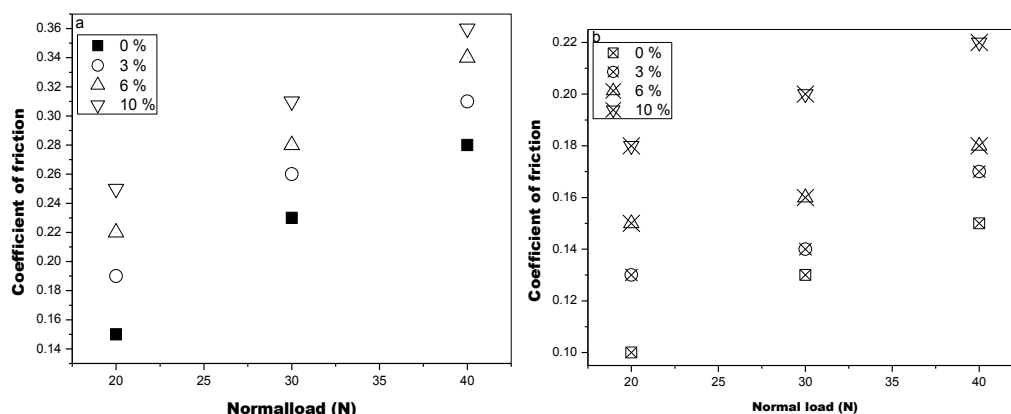

Figure 6. Coefficient of friction versus normal load at abrading distance (a) 100 m and (b) 200 m of bare vinyl ester and VE/WSP green composites

SEM studies

The surface morphology of the worn surfaces of the composites was examined using a scanning electron microscope. The SEM features of eroded surface of pristine vinyl ester, 6 wt. % and 10 wt. % walnut shell powder filled vinyl ester composites at 10 N and 200 m sliding distance which are shown in Figure 7 (a)-(c) respectively. It depicts more severe damages to matrix and wear loss is more for pristine vinyl ester. The SEM image of 3 % WSP filled vinyl ester

composite indicates deep and wider furrows. However, the green composite with 10 % walnut shell powder showed that less damage to the polymer matrix, as compared to other composites, and better wear resistance were obtained by addition of walnut shell powder in vinyl ester polymer matrix. This can be attributed to that incorporation of rigid walnut shell powder filler which improves the wear resistance of the composites. Specific wear rate and wear loss data were supported by SEM study.

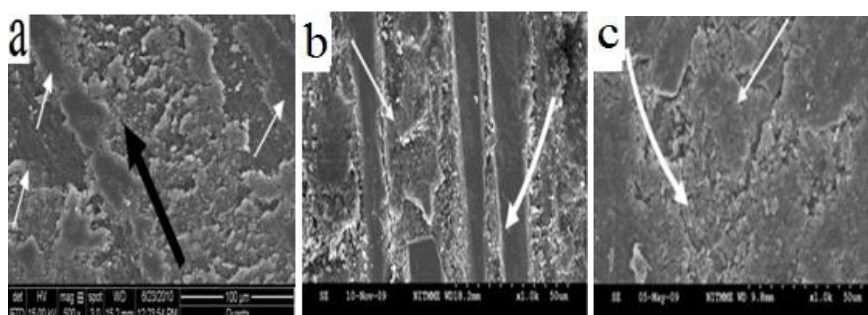

Figure 7. SEM images of (a) neat vinyl ester, (b) 6 % WSP and (c) 10 % walnut shell powder loaded green composites at 10 N load and 200 m distance

Conclusion

Physical properties and sliding wear behavior of varying amounts of walnut shell powder filled VE/WSP green composites have been investigated. The study on physical and mechanical properties of walnut shell powder reinforced vinyl ester composites

revealed that these properties are affected by filler content. A marked improvement in tensile properties was found with increase in walnut shell powder content in the composite. However, improvement in tensile modulus and surface hardness with increase in filler content in vinyl ester

matrix was noticed. Wear resistance improved as increase in walnut shell powder content in the composites. Composite with 10 % WSP content exhibits lowest specific wear rate for both sliding distance and at all three loads as compared to other composites. Specific wear rate and coefficient of friction decrease on addition of walnut shell powder into matrix polymer. Green composite with WSP content of 10wt. % has the lowest specific wear rate and coefficient of friction. SEM photomicrographs revealed that the walnut shell powder was detrimental to abrasive wear in composites. Decrease in coefficient of friction is due to the combined three body roller bearing action of both filler and filler-reinforced wear debris and also due to the formation of thin transfer film on the counter face.

Acknowledgments

The authors thank Siddaramaiah from the Department of Polymer Science and Technology, Sri Jayachamarajendra College of Engineering, Mysore, India, for her great help.

References

- [1] E. Bozkurt, E. Kaya, M. Tanoglu, *Comp Sci Tech.*, **2007**, *67*, 3394–3403.
- [2] M.W. Nielsen, J.W. Schmidt, J.H. Hogh, J.P. Waldbjorn, J.H. Hattel, T.L. Andersen, C.M. Markussen, *J Comp Mat*, **2014**, *48* (3), 365-381.
- [3] W. Hufenbach, K. Kunze, J. Bijwe, *J Synth Lub*, **2013**, *20*(3), 227-240.
- [4] M.N. Islam, M.R. Rahman, M.M. Haque, M.M. Huque, *Comp Part A*, **2010**, *41*, 192–198.
- [5] M. Krzesinska, J. Zachariasz, A.I. Lachowski, *Bio Tech*, **2009**, *100*, 1274–1278.
- [6] A. Arbelaiz, B. Fernandez, A. Valea, I. Mondragon, *Carbo Polym*, **2006**, *64*, 224–232.
- [7] M. Assarar, D. Scida , A.El Mahi , C. Poilâne , R. Ayad, *Mate Des*, **2011**, *32*,788–795.
- [8] Y. Mohd Yuhazri, P.T. Phongsakorn, H. Sihaming, *Int J Bas Appl Sci*, **2010**, *10*(3), 63-66.
- [9] S. Pashaei, B. Siddaramaiah, A.A. Syed, *Polym-Plast Tech Eng*, **2011**, *50* (10), 973-982.
- [10] B.D. Agarwal, L.J. Broutman, *John Wiley and Sons*, New York, (1990).
- [11] J.P. Dhal, S.C. Mishra, *Journal of Materials*, **2013**, *32*, 1-6.
- [12] B. Gangil, A. Patnaik, A. Kumar, M. Kumar, *J Mat Des Appl*, **2012**, *226* (4), 300- 315.
- [13] A.A.Yussuf, I. Massoumi, A. Hassan, *J Polym the Env*, **2010**, *18*(3), 422-429.
- [14] K. Salasinska, J. Ryszkowska, *Comp Inter*, **2012**, *19*(5), 321-332.
- [15] H. Pihlil, N. Tosun, *Wear*, **2002**, *252*, 979–984.
- [16] G. Agarwal, A. Patnaik, R.K. Sharma, *AdvComp*, **2014**, *23*, 293-317.
- [17] M.B.J. LOW, *Wear*, **1979**, *52*, 347– 363.
- [18] Gaura Agarwal, Amar Patnaik, Rajesh Kumar, *Int J Eng Res Appl (IJERA)*, **2012**, *6*(2), 1148-1167.
- [19] M.A. Chowdhury, M.M. Helali, *Trib Int*, **2009**, *42*, 946-950.
- [20] B.Bhushan, A.V. Kulkarni, *Thin Sol Fil*, **1996**, *278*, 49-56.